

## ① PHYSICAL DIMENSION/外型尺寸

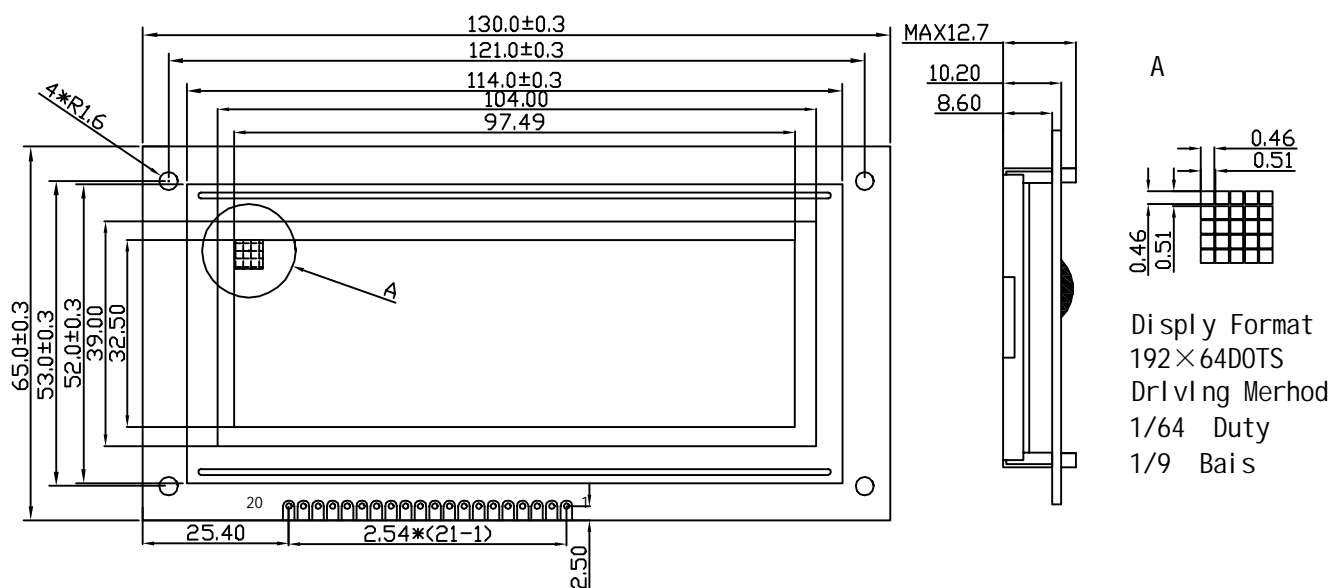

## ② FEATURES/特征

Feature(特征)	UNIT(单位)
LCD type & Colour(类型及颜色)	STN Yellow-green ; STN Blue
View Angle(视角)	6 O'clock
Operating temperature(工作温度)	-20°C ---- 70°C
Storage Temperature(贮存温度)	-30°C ---- 80°C
Control IC & Package(控制芯片及封装)	S6B0107 , COB
Weight(重量)	101 (With B/L)
Backlight(背光类型)	LED

Ta=25°C	MIN(最小)	TYP(典型)	MAX(最大)	UNIT(单位)		
Supply current don't contain backlight(无背光时电流)	0	9.2		mA		
VDD(电源)	-0.3	3.0	5.0	5.5	V	
VLCD-V0(LCD驱动电压)	0	-4.7		V		
Backlight LED (背光电压, 电流)	侧背光	0	3.0	5.0	5.0	V
	底背光		0	75		mA
			0	5.0	5.5	V
			0	180		mA

## ④ BLOCK DIAGRAM/原理电路

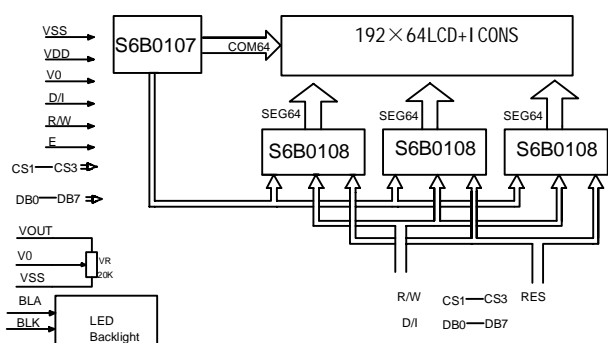

## ③ PIN CONFIGURATION/管脚说明

PIN	SYMBOL	DESCRIPTION(定义描述)	
1	VSS	Power ground (地)	
2	VDD	Power positive(逻辑电压)	
3	V0	Operating voltage for LCD Driver(对比度调节)	
4	D/I	H:Data L: Instruction Code(指令 数据信号)	
5	R/W	Read or Write.(写数据)	
6	E	Enable trigger.(使能信号)	
7	DB0	Data bus [0-7]. There state I/O common terminal.(数据线0-7)	
14	DB7		
15	CS1		Chip select signal(片选1)
16	RST		Reset Signal(复位)
17	CS2		Chip select signal(片选2)
18	CS3		Chip select signal(片选3)
19	VOUT		Negative voltage output(负压输出)
20	BLA		Power supply for backlight(+)(背光正极)

## ⑤ ELUCIDATION/补充备注